

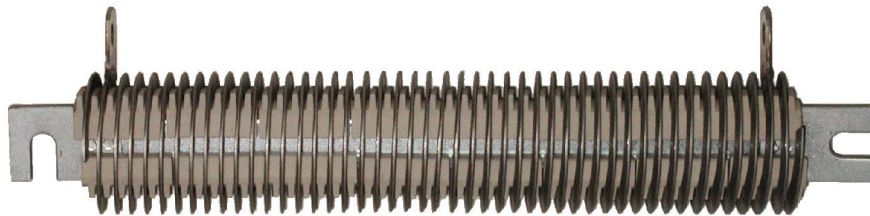

Edgewound Resistors



Hardware Reference

Document 1101023 - Edition June 2009

Table of Contents

1	General Description.....	3
2	Product Selection Guide.....	4
3	TOFIL and BC Series	
3.1	General Description.....	5
3.2	Electrical and Thermal Specifications	
3.2.1	Resistance ribbons.....	5
3.2.2	Ohmic values.....	7
3.2.3	Continuous duty.....	10
3.2.4	Instantaneous discharge.....	11
3.2.5	Short time duty.....	12
3.2.6	Intermittent periodic duty.....	13
3.2.7	Voltage insulation.....	13
3.2.8	Inductance.....	14
3.3	Mechanical Specifications	
3.3.1	Mounting styles overview table.....	15
3.3.2	Dimensions.....	16
3.3.3	Terminals.....	20
3.3.4	Weights.....	21
3.4	Product Identification Code.....	22
4	Special Series and Models	
4.1	ZOFIL Series.....	22
4.2	M17 Series.....	23
5	Edgewound Resistor Assemblies	
5.1	Open frame constructions.....	24
5.2	Resistor enclosures.....	25

COUDOINT

Tel.: +33 1 30 41 55 00

Fax: +33 1 30 41 55 62

Email: commercial@coudoint.comWebsite: www.coudoint.com

Address: 19 Avenue de la gare 78690 Les Essarts Le Roi FRANCE

1 General Description

Edgewound resistors are characterized by :

- **high currents**: continuous rated currents up to 103 A, in short time duty up to 1650 A
- **low ohmic values from** 0.018 ohm
- **high energy absorption** during instantaneous discharges up to 527 kilojoules

» Series and models:

Coudoint standard edgewound resistors are offered in the TOFIL Series and BC Series. Other special series and models are available as well.

Resistor assemblies can be supplied as open frames, available to OEMs for mounting in their own enclosure, or in indoor/outdoor enclosures according to a specified IP level.

The Coudoint technical sales department is at your disposal to help you choose or define a solution to meet your needs for of resistive loads.

» Description: Edgewound resistors are constructed with:

- a coil of edgewound heavy resistance alloy ribbon,
- grooved insulators supporting this coil,
- terminals which are welded to the resistance element,
- optional intermediary terminals: fixed (welded) or adjustable,
- mounting hardware : brackets, threaded rod, etc.

» TOFIL and BC Series

- the two series use the same resistance coils and have overall, for an equal number of turns, the **same electrical and thermal characteristics**
- they differ in in the mechanical design, with an insulated support of the coil made with:
 - for the TOFIL resistors: a one-piece grooved ceramic tube
 - for the BC resistors: toothed ceramic insulators supported by a zinc-plated steel mounting bar
- the two series share:
 - a set of **21 types (lines) of resistance ribbon** using 4 different types of alloy
 - a set of **7 standard models** with 7 standard coil lengths: TOFIL-1 to TOFIL-7 and BC-1 to BC-7
- beyond this standard:
 - 2 longer standard BC models are available: BC-8 and BC-9
 - a longer TOFIL ceramic core can be used for designing resistors beyond the TOFIL-7 model
- **every ohmic value can be supplied in the range of** feasibility in the **TOFIL (0.018 to 3.9 Ω) and BC (0.018 to 5.1 Ω)** series.
- TOFIL and BC resistors are ROHS compliant

» Other series and models, edgewound resistor assemblies :

We can supply other series --such as ZOFIL series for traction (railway) applications, etc.-- and models than those found in this document, with special characteristics (reduced tolerances at ambient or in the full temperature range, multiple resistors on the same structure, etc.). Please contact us.

Old models (M17, etc.) can be supplied depending on the availability of the components. If necessary, we can suggest a replacement solution.

When a single resistor cannot fulfill the requirement, we can offer resistor assemblies - open frame constructions or enclosures - with resistors from different series.

» Temperature rise:

All data are given here for a resistor in horizontal position, alone, in free-air cooling conditions.

For a resistor assembly, as an open frame or in an enclosure, or in forced-air cooling, Please contact us.

» Tolerances:

Standard tolerance on the ohmic value is $\pm 5\%$ at ambient temperature (25°C) - for more than 10 turns.

Reduced tolerances are available on request.

The variation of the ohmic value with the temperature depends on the type of alloy used for the resistance coil.

All data provided in this document are approximate values because of the component and process tolerances. Contractual values are only those mentioned on the commercial document for each specific proposal.

2 Product Selection Guide

The table below may be used to select a **TOFIL** or **BC** edgewound resistor for a given requirement: select the resistance alloy, then the cross-sectional size of the ribbon. Then, with the tables on the following pages, select the model corresponding to the required ohmic value or energy level. If a solution cannot be found, a resistor assembly may be required.

An easy way to select a resistor is to describe what you need to us and we will suggest an optimized solution.

Selection of the alloy according to :		Ribbon selection (= number of the line) meeting the required current level :			Selection of the model meeting:	
- the general criteria regarding the application - the ohmic value variation ΔR vs. temperature between ambient and nominal values		- in continuous duty: I_{NOM} - in short time duty: I_{INT} (see p.12)			- the required ohmic value - the required energy in instantaneous discharge (p. 11) with tables on pages 7 to 9	
General criteria regarding the application	ΔR for $\Delta=100^{\circ}C$	Line N°	I_{NOM} (A)	I_{INT} Max. (A)	Ohmic values	Instantaneous energy
Alloy A: "Silver nickel" - very low ohmic values - high currents - good stability over temperature	+0.8 %	Line 1	103	1,650	0.018 to 0.21 Ω	46 to 534 kJ
		Line 2	93	1,300	0.022 to 0.26 Ω	39 to 451 kJ
		Line 3	84	1,000	0.028 to 0.33 Ω	29 to 338 kJ
Alloy B: "Stainless steel" - cost advantage - poor stability over temperature - good overload capacity	+10 %	Line 4	78	1,200	0.041 to 0.48 Ω	59 to 689 kJ
		Line 5	59	800	0.057 to 0.67 Ω	37 to 429 kJ
		Line 6	52	600	0.077 to 0.89 Ω	27 to 313 kJ
		Line 7	42	400	0.113 to 1.32 Ω	19 to 216 kJ
		Line 8	36	310	0.147 to 1.72 Ω	14 to 164 kJ
Alloy C: "Chromium-Aluminum" - used as a standard - good stability over temperature - good overload capacity	+1 %	Line 9	42	500	0.113 to 1.32 Ω	27 to 317 kJ
		Line 10	36	375	0.147 to 1.72 Ω	21 to 247 kJ
		Line 11	32	285	0.196 to 2.28 Ω	16 to 183 kJ
		Line 12	29	235	0.22 to 2.56 Ω	13 to 151 kJ
		Line 13	24	165	0.32 to 3.73 Ω	9 to 109 kJ
		Line 14	21	120	0.44 to 5.12 Ω	7 to 76 kJ
Alloy D: "Nickel-Chromium" - good stability over temperature - good overload capacity - very good resistance to corrosion - low amount of iron (magnetic effect) - for demanding applications : railway, marine applications, etc.	+1,8 %	Line 15	52	750	0.077 to 0.89 Ω	44 to 513 kJ
		Line 16	42	510	0.113 to 1.32 Ω	30 to 345 kJ
		Line 17	36	400	0.147 to 1.72 Ω	23 to 269 kJ
		Line 18	32	290	0.196 to 2.28 Ω	17 to 199 kJ
		Line 19	29	250	0.22 to 2.56 Ω	14 to 165 kJ
		Line 20	24	170	0.32 to 3.73 Ω	10 to 119 kJ
		Line 21	21	120	0.44 to 5.12 Ω	7 to 83 kJ

3 TOFIL and BC Series

3.1 General Description

The resistors in the **TOFIL and BC series use the same edgewound resistance coils**, with a higher maximum number of turns for the BC series (BC-8: 93 turns and BC-9: 105 turns) than the TOFIL series (84 turns maximum).

The electrical and thermal characteristics of the resistors are the same for a given line and number of turns .

The terminals and optional intermediary lugs are the same in the two series,

The difference between the resistors in the two series resides in the mechanical structure supporting the resistance coil and then in their dimensions:

- The TOFIL resistors are constructed with a one-piece grooved ceramic tube:



The length of the ceramic tube, and of the resistor, can be adapted to match the required ohmic value.

- The BC resistors use toothed ceramic insulators supported by a zinc plated steel mounting bar. The bar is slotted at both ends:



The length of the BC resistors are the same as in the standard model, for which the mounting bars have been designed to match the possible combinations of the ceramic jumpers, and only 9 sizes are available.

3.2 Electrical and Thermal Specifications

3.2.1 Resistance ribbons

Twenty_one types of resistance ribbon are used in the standard models. Each type is designated by the corresponding line number in the Product Selection Guide - line 1 to line 21 - and is characterized by the type of the alloy - in the 4 possibilities - and by the cross-sectional size of the resistance ribbon.

♦ **Alloys:** The 4 types of alloys used for the standard models are:

- **Alloy A: Silver-nickel**
 - used for lines 1 to 3
 - nominal composition: copper (~63%), zinc (~22%) and nickel (~15%)
 - resistivity: $31 \Omega \cdot \text{mm}^2 \cdot \text{m}^{-1}$ at 25°C
 - coefficient of resistivity (vs temperature) lower than 80 ppm/°C.

This alloy is suitable when low ohmic values, high currents and a low temperature coefficient of resistance are required.

This alloy is corrosible when used in chemical industry.

- **Alloy B: Stainless steel**
 - used for lines 4 to 8
 - nominal composition: iron (~72%), nickel (~19%) and chromium (~9%)

- resistivity: $73 \Omega \cdot \text{mm}^2 \cdot \text{m}^{-1}$ at 25°C
- coefficient of resistivity (vs. temperature): $\sim 1000 \text{ ppm}/^\circ\text{C}$.

This alloy is suitable for applications where cost is the primary factor and where a low temperature coefficient of resistance is not required.

- **Alloy C: Chromium-aluminum**

- used for lines 9 to 14
- nominal composition: iron ($\sim 80\%$), chromium ($\sim 13\%$), aluminum ($\sim 5\%$) and manganese ($\sim 0.8\%$)
- resistivity: $122 \Omega \cdot \text{mm}^2 \cdot \text{m}^{-1}$ at 25°C
- coefficient of resistivity (vs. temperature) lower than $100 \text{ ppm}/^\circ\text{C}$.

This alloy is used as a standard because of its very good cost/performance ratio, and especially the stability of the ohmic value versus temperature.

- **Alloy D: Nickel-chromium**

- used for lines 15 to 21
- nominal composition: nickel ($\sim 60\%$), iron ($\sim 25\%$) and chromium ($\sim 15\%$)
- resistivity: $112 \Omega \cdot \text{mm}^2 \cdot \text{m}^{-1}$ at 25°C
- coefficient of resistivity (vs. temperature) lower than $180 \text{ ppm}/^\circ\text{C}$.

This alloy performs well and has a particularly strong resistance to corrosion and a very stable resistivity versus temperature. Due to the low amount of iron, it is not very sensitive to the magnetic susceptibility effect. For these reasons, it is usually selected for the most demanding applications such as railway and marine applications.

◆ **Lines of resistance ribbon:**

Each line of resistance ribbon – line 1 to line 21 – refers to a specific alloy and sectional size combination. The cross-sectional sizes have been selected in order to have a globally coherent set of ohmic values for each alloy as well as a level of standardization between the different alloys groups: several lines of resistance ribbon with different types of alloys have the same ohmic value per turn and the same continuous rated current.

This is shown in table 1 where the ohmic values by turn R_{turn} are given for each line by type of alloy : some lines using different types of alloy have the same ohmic value per turn and the same rated current. The performances of these lines differ, of course, in terms of:

- temperature coefficient of resistance, this coefficient depends on the alloy
- level of energy which can be absorbed during an instantaneous discharge: this value depends on the volumetric mass and the specific heat of the alloy as well as on the cross-sectional size of the resistance ribbon.

Alloy A	Alloy B	Alloy C	Alloy D	R_{turn} (m Ω)	I_{perm} (A)
Line 1				2.0	103
Line 2				2.5	93
Line 3				3.1	84
	Line 4			4.5	78
	Line 5			6.3	59
	Line 6			Line 15	8.5
	Line 7	Line 9	Line 16	12.6	42
	Line 8	Line 10	Line 17	16.3	36
		Line 11	Line 18	22	32
		Line 12	Line 19	24	29
		Line 13	Line 20	38	24
		Line 14	Line 21	49	21

Table 1: (approximate) Ohmic values by turn and continuous rated currents for each line TOFIL or BC

» Number of turns

The approximate ohmic value per turn given in table 1 can be used to select a standard model in the TOFIL or BC series according to table 2 or to check the feasibility, the number of turns must be between:

- **9 to 84 turns for TOFIL** resistors
- **9 to 105 turns for BC** resistors

These limits may vary depending on the required insulation voltage (standard dielectric voltage : 1,500 V).

	TOFIL-1	TOFIL-2	TOFIL-3	TOFIL-4	TOFIL-5	TOFIL-6	TOFIL-7		
	BC-1	BC-2	BC-3	BC-4	BC-5	BC-6	BC-7	BC-8	BC-9
Number of turns	9	20	33	45	55	68	80	93	105

Table 2: Number of turns for the TOFIL and BC standard models

3.2.2 Ohmic values

» Standard ohmic values

Number of lines per type of alloy				Ohmic values for the standard models (Ω)									
				TOFIL-1	TOFIL-2	TOFIL-3	TOFIL-4	TOFIL-5	TOFIL-6	TOFIL-7			
A	B	C	D	BC-1	BC-2	BC-3	BC-4	BC-5	BC-6	BC-7	BC-8	BC-9	
1				0.018	0.040	0.065	0.089	0.109	0.135	0.158	0.184	0.21	
2				0.022	0.050	0.082	0.112	0.136	0.169	0.198	0.23	0.26	
3				0.028	0.063	0.104	0.142	0.173	0.21	0.25	0.29	0.33	
	4			0.041	0.091	0.150	0.20	0.25	0.31	0.36	0.42	0.48	
	5			0.057	0.127	0.21	0.29	0.35	0.43	0.51	0.59	0.67	
	6		15	0.077	0.170	0.28	0.38	0.47	0.58	0.68	0.79	0.89	
	7	9	16	0.113	0.25	0.42	0.57	0.69	0.86	1.01	1.17	1.32	
	8	10	17	0.147	0.33	0.54	0.74	0.90	1.11	1.31	1.52	1.72	
		11	18	0.196	0.44	0.72	0.98	1.20	1.48	1.74	2.02	2.28	
		12	19	0.22	0.49	0.80	1.10	1.34	1.66	1.95	2.26	2.56	
		13	20	0.32	0.71	1.17	1.60	1.96	2.42	2.85	3.31	3.73	
		14	21	0.44	0.97	1.61	2.19	2.68	3.31	3.90	4.53	5.12	

Table 3: Standard ohmic values for TOFIL and BC series

» Possible ohmic values

Every ohmic value may be supplied in the range of values given for each line of the TOFIL and BC series. The curves in diagrams 1 and 2 show the ohmic values for a given number of turns for the different lines of resistance ribbon, while also pointing out the continuous current for each.

Diagram 1 is for ohmic values above 1 ohm and diagram 2 is for lower values.

The limits corresponding to the BC series and to the TOFIL series are given at the top of each diagram. The standard values are indicated by dotted lines, above which the number of each standard model is given.

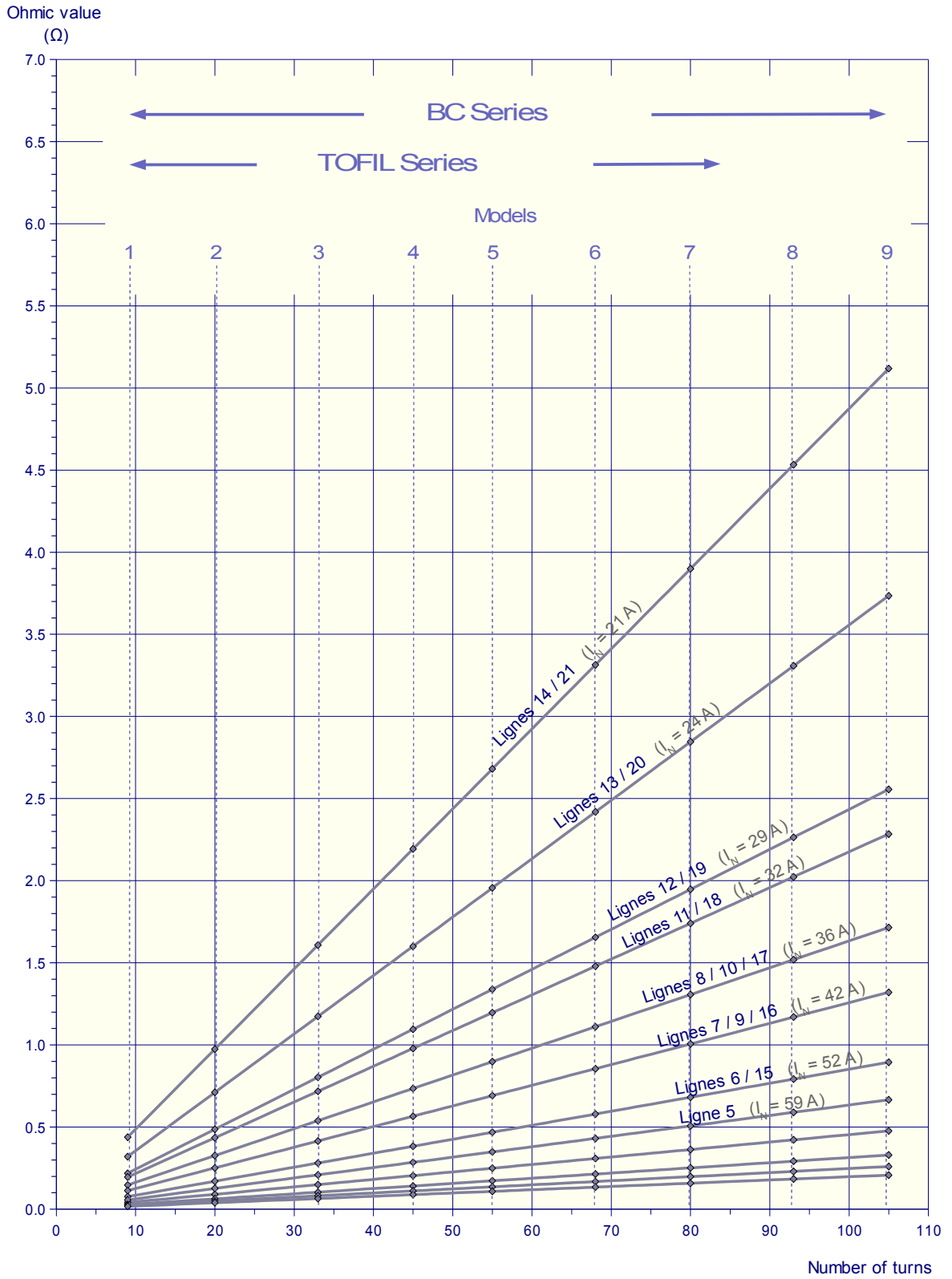

Diagram 1: Ohmic values (high values) vs. number of turns

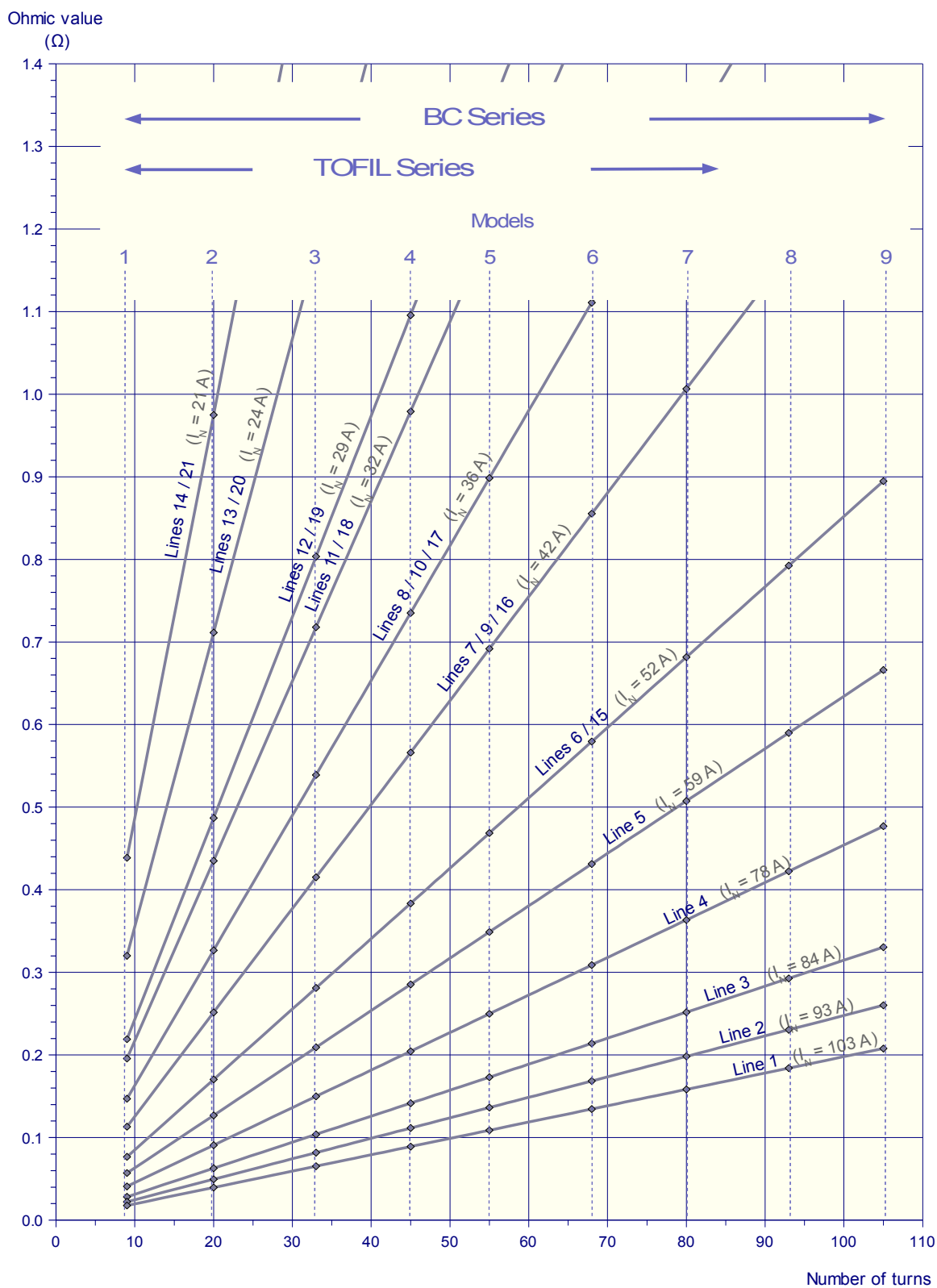

Diagram 2: Ohmic values (low values) vs. number of turns

3.2.3 Continuous duty

» **Rated current**

Rated current values are given in table 1 and diagrams 1 and 2. These values are for an ambient temperature of 25°C and for a temperature rise in the resistance coil of 375°C. For lines 4 to 21, the temperature rise in continuous duty can reach 450°C under specific conditions.

The rated power can be significantly increased by forced-air cooling. Please contact us.

» **Rated current derating**

When the ambient temperature is above 25°C, the rated current is reduced by a coefficient along the curve in diagram 3:

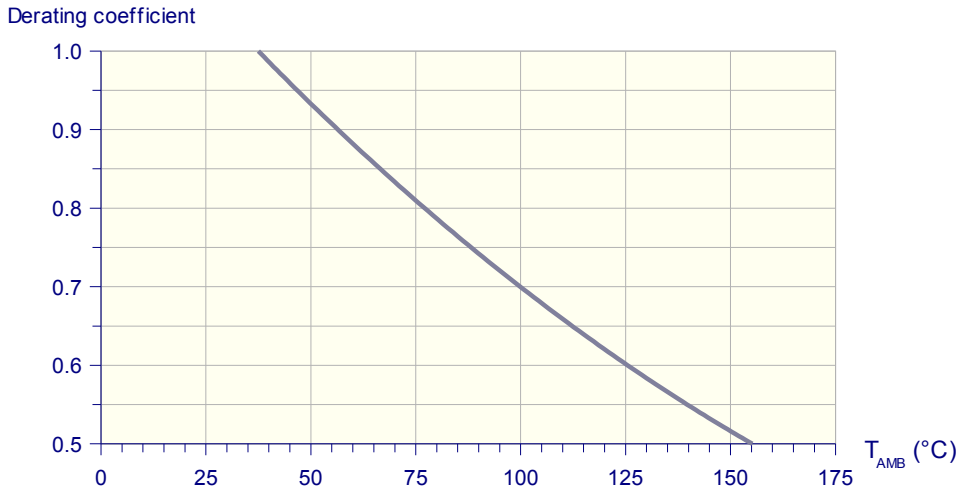

Diagram 3: Rated current derating curve

» **Variation of the temperature of the coil**

The temperature rise in the resistance coil depends on the current level. The curves in diagram 4 give the value of the temperature range vs. the current level for the different lines:

Temperature rise (°C)

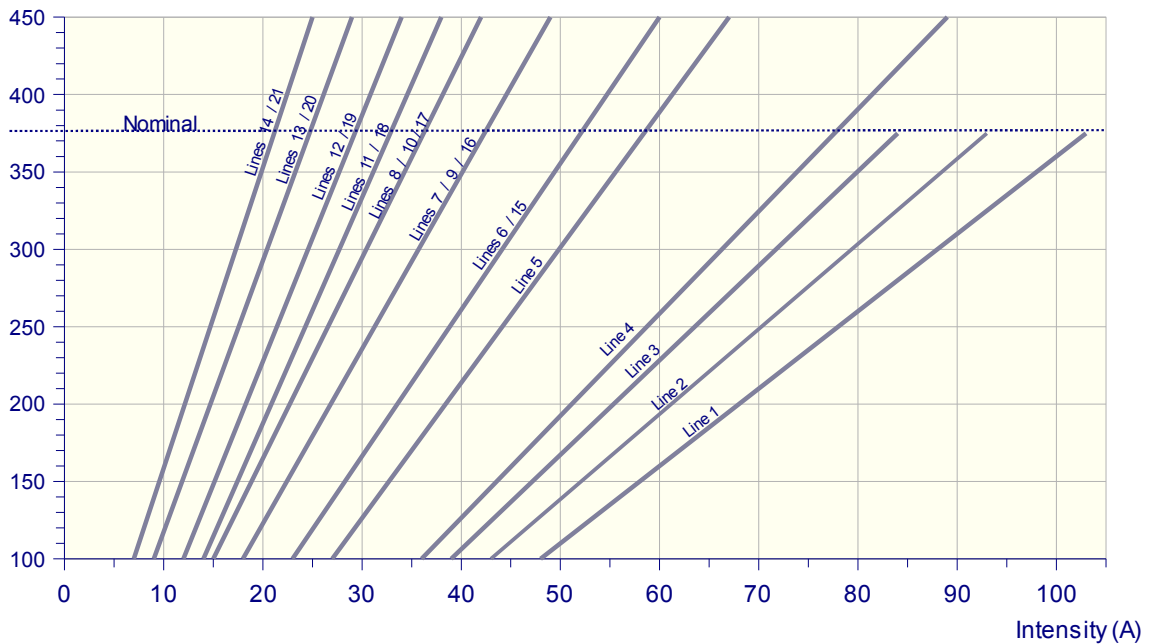

Diagram 4: Temperature rise of the resistance coil vs continuous current

3.2.4 Instantaneous discharge

This occurs when there is a quick discharge through the resistor – theoretically instantaneous, practically a few tenths of a second – which is not repeated, at least until the resistance coil is back to its initial temperature. These conditions, with the acceptable overload levels of the resistance coils (400°C for the lines 1 to 3 and 600°C for the other lines), make it possible for the resistor to absorb an energy of a value E given in table 4 for the standard models of the TOFIL and BC series:

(kilojoules)	TOFIL-1	TOFIL-2	TOFIL-3	TOFIL-4	TOFIL-5	TOFIL-6	TOFIL-7		
	BC-1	BC-2	BC-3	BC-4	BC-5	BC-6	BC-7	BC-8	BC-9
Line 1	46	102	168	229	279	346	406	473	534
Line 2	39	86	142	193	236	292	344	400	451
Line 3	29	64	106	145	177	219	257	299	338
Line 4	59	131	217	295	361	446	525	611	689
Line 5	37	82	135	184	225	278	327	380	429
Line 6	27	60	98	134	164	203	239	277	313
Line 7	19	41	68	93	113	140	165	192	216
Line 8	14	31	52	70	86	106	125	146	164
Line 9	27	60	100	136	166	205	241	281	317
Line 10	21	47	78	106	129	160	188	219	247
Line 11	16	35	57	78	96	118	139	162	183
Line 12	13	29	47	65	79	98	115	134	151
Line 13	9	21	34	47	57	71	83	97	109
Line 14	7	15	24	33	40	50	58	68	76
Line 15	44	98	161	220	269	332	391	454	513
Line 16	30	66	108	148	181	223	263	306	345
Line 17	23	51	85	115	141	174	205	238	269
Line 18	17	38	62	85	104	129	151	176	199
Line 19	14	31	52	71	86	107	125	146	165
Line 20	10	23	37	51	62	77	91	105	119
Line 21	7	16	26	36	44	54	64	74	83

Table 4: Acceptable instantaneous energy (in kilojoules) by model and line

3.2.5 Short time duty

In this type of duty, the current flows through the resistor during a “current flow time” T_A , typically from one to several tens of seconds, then the resistor cools down during the rest time T_R , this value depends on the resistance coil and on the line number of the resistor. Table 5 gives the value of the rated current per line number for values of T_A from one second to one minute, with the minimum rest-time value T_R indicated for each line number:

(ampères)	Current flow time T_A (s)											Minimum rest time T_R (s)
	1	1,5	2	3	4	5	7	10	20	30	60	
Line 1	1650	1300	1100	850	720	625	520	420	280	235	175	1850
Line 2	1300	1050	870	680	570	500	420	335	230	185	150	1450
Line 3	1000	800	670	530	450	400	300	275	185	165	130	1200
Line 4	1200	930	680	600	510	450	370	300	200	170	130	2200
Line 5	800	620	520	400	340	300	250	200	145	125	97	1700
Line 6	600	455	380	300	260	230	185	160	120	96	80	1100
Line 7	400	325	275	220	190	170	140	120	82	70	60	800
Line 8	310	250	210	170	145	130	107	87	65	57	48	600
Line 9	500	400	340	275	240	215	180	151	112	90	67	1350
Line 10	375	310	265	215	185	165	140	120	85	70	53	1000
Line 11	285	230	195	165	145	130	110	91	65	55	43	750
Line 12	235	190	165	140	120	112	90	75	54	45	38	650
Line 13	165	138	120	94	80	72	62	52	39	34	29	600
Line 14	120	98	85	69	60	53	46	39	30	27	23	450
Line 15	750	600	510	410	350	310	267	215	155	130	84	1600
Line 16	510	415	350	280	240	215	180	150	110	90	69	1200
Line 17	400	320	270	215	180	165	140	120	83	70	55	950
Line 18	290	235	190	165	140	125	105	90	67	57	53	700
Line 19	250	200	175	140	125	110	90	77	58	51	42	600
Line 20	170	145	120	98	85	75	67	57	44	40	33	500
Line 21	120	98	85	69	60	54	47	43	33	30	26	450

Table 5: Acceptable current levels per line in short time duty

3.2.6 Intermittent periodic duty

In this type of duty, the current flows across the resistor for a period of time T_1 , then stops ($I = 0$) during the rest time T_2 , and then a new cycle starts: the cycle time is $T = T_1 + T_2$.

At the end of the rest time, the resistance coil is at an intermediary temperature between the temperature which would be reached in continuous duty and the ambient temperature. Table 6 gives the acceptable currents for each line - except for those corresponding to the alloy B, which is not used in these applications due to its high TCR (Temperature Coefficient of Resistance) – for a set of values of the cycle time T and of the duty cycle $d = T_1/T$:

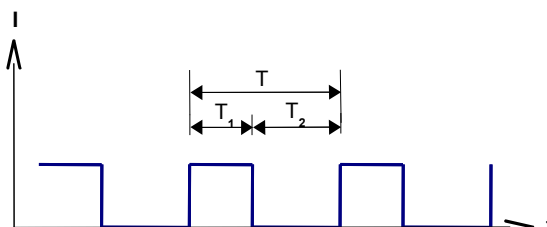

Cycle time T (s)	15	15	15	60	60	60	240	240	240
$d = T_1/T$	15%	30%	50%	15%	30%	50%	15%	30%	50%
T_1 (s)	2.3	5	7.5	9	18	30	36	72	120
T_2 (s)	12.7	10	7.5	51	42	30	204	168	120
Line 1	290	190	145	270	190	146	230	170	140
Line 2	260	160	140	220	174	134	182	142	118
Line 3	230	145	115	220	154	120	160	124	106
Line 15	145	90	70	130	96	72	108	80	66
Lines 9 and 16	115	70	56	110	77	58	83	65	52
Lines 10 and 17	97	62	48	92	82	47	70	56	45
Lines 11 and 18	90	55	45	70	52	42	58	47	40
Lines 12 and 19	82	52	41	78	55	42	55	43	37
Lines 13 and 20	45	34	30	47	35	28	40	31	27
Lines 14 and 21	52	33	26	38	28	23	33	27	22

Table 6: Acceptable current levels (in amps) per line in intermittent periodic duty

3.2.7 Voltage insulation

❖ **Operating voltage**

TOFIL and BC resistors are designed to operate under voltages up to 440 V_{AC} or 350 V_{DC} .

❖ **Insulation voltage**

The insulation voltage (between the resistance coil and mounting brackets) of each TOFIL or BC resistor is checked in production under a voltage of 1,500 V_{AC} /50 Hz.

When a higher insulation voltage is required :

- the dimension of the TOFIL resistors is adjusted to increase the distance between the coil and the brackets.
- an optional "secondary insulation" feature allows an increase in the insulation voltage of the BC-3 to BC-9 resistors above 5,000 V (depending on the complete mounting structure). See description on page 19.

❖ **Insulation resistance**

The insulation resistance (between the resistance coil and mounting brackets) is higher than 100 $M\Omega$ under a DC voltage of 500 V . This point is checked in production on each unit.

3.2.8 Inductance

The inductance value of the TOFIL or BC resistor vs. the number of turns is given by the curve in diagram 5. The curve shows only an approximate value, other parameters must be taken into account, such as the presence of a treading rod (TOFIL) or of intermediary lugs. If this value is important for the application, special precautions can be taken to limit its value. Please contact us.

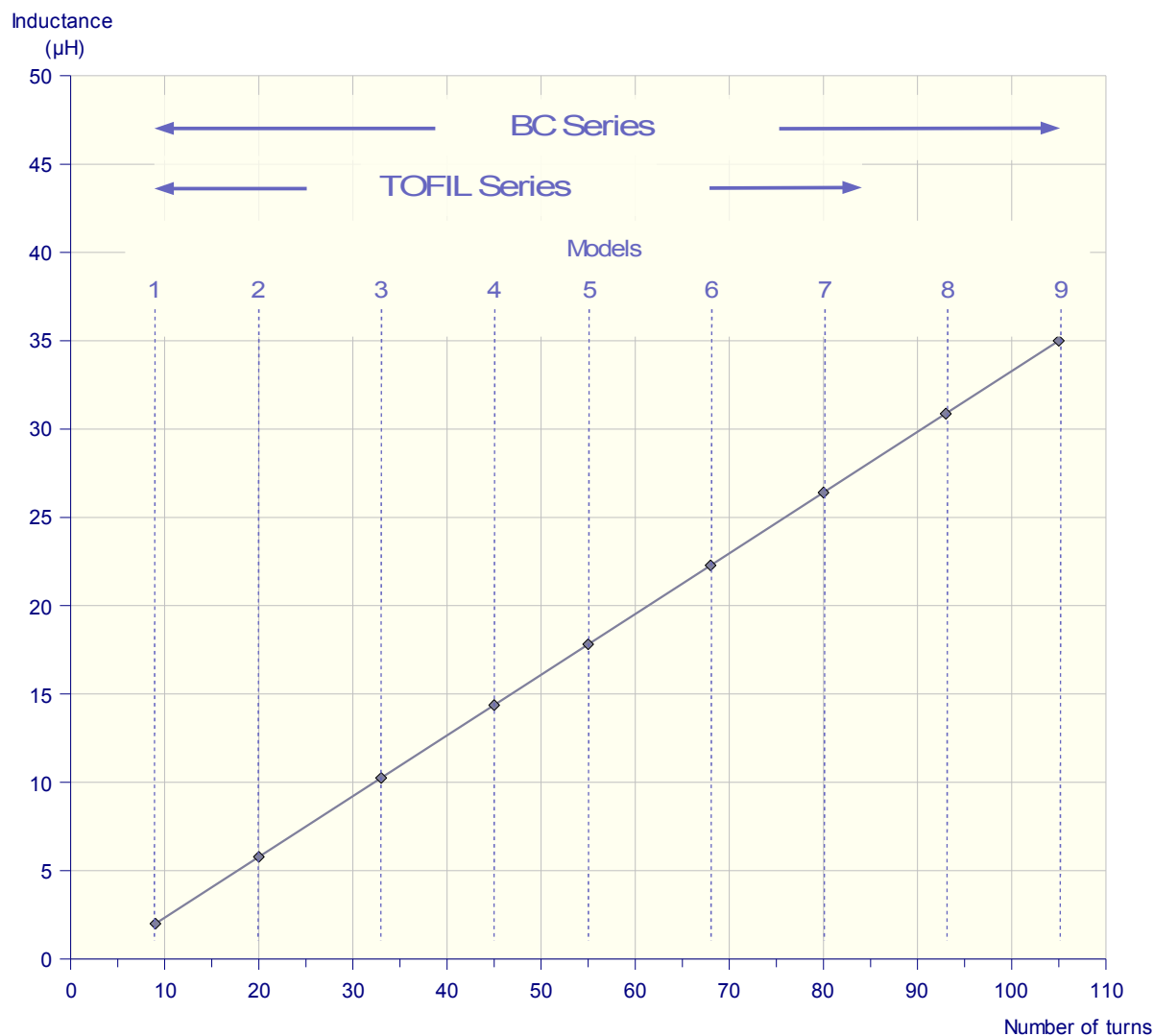
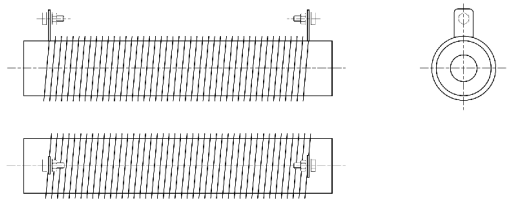
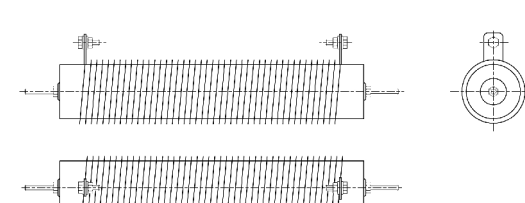
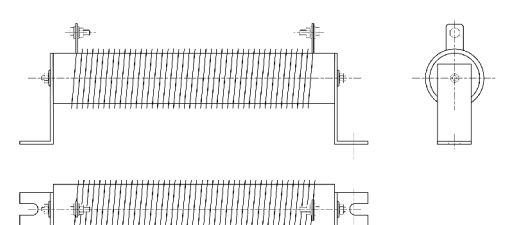
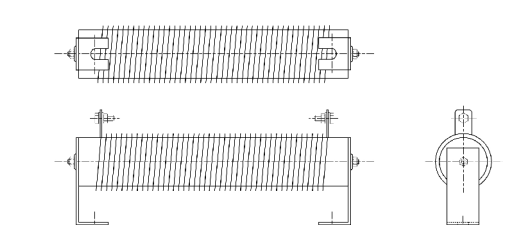
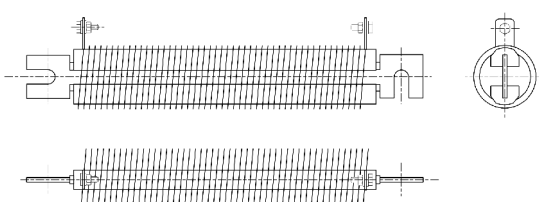
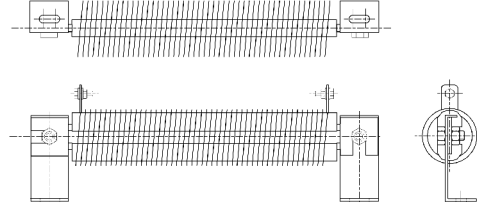
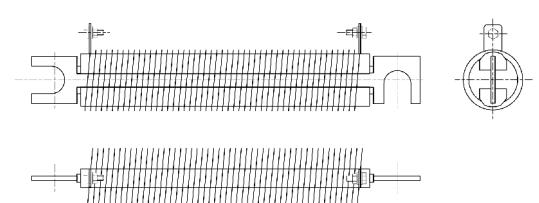
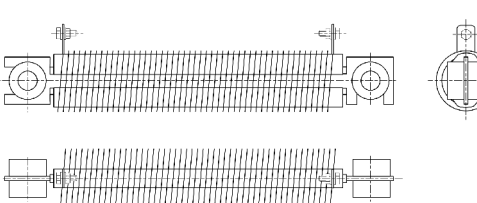

Diagram 5: Inductance value for TOFIL and BC resistors

3.3 Mechanical Specifications

3.3.1 Mounting styles overview table

TOFIL	 <p style="text-align: center;">Unmounted</p>	 <p style="text-align: center;">With threaded rod</p>
	 <p style="text-align: center;">PS mounting brackets</p>	 <p style="text-align: center;">ID mounting brackets</p>
BC	 <p style="text-align: center;">Unmounted</p>	 <p style="text-align: center;">PS mounting brackets</p>
	 <p style="text-align: center;">For secondary insulation (without insulators)</p>	 <p style="text-align: center;">With secondary isolation (with insulators)</p>

3.3.2 Dimensions

TOFIL:

- Unmounted resistor

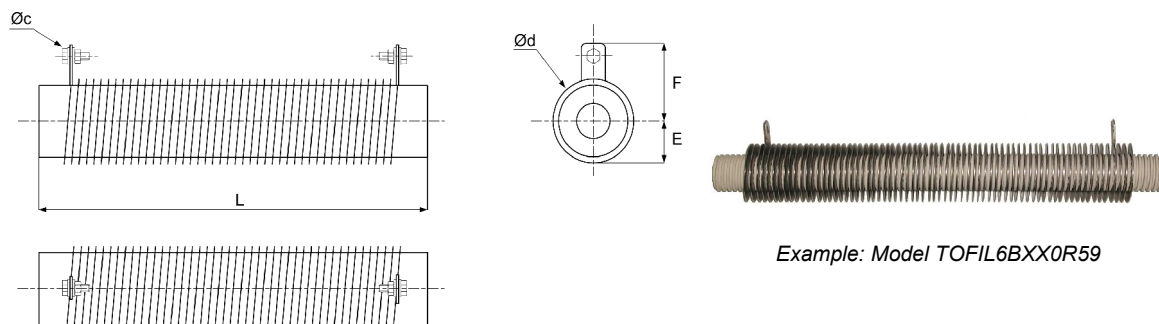

Example: Model TOFIL6BXX0R59

(mm)	TOFIL-1	TOFIL-2	TOFIL-3	TOFIL-4	TOFIL-5	TOFIL-6	TOFIL-7
L	90	156	236	306	366	444	516
Øc	8.5	8.5	8.5	8.5	8.5	8.5	8.5
Ød¹	56	56	56	56	56	56	56
E	28	28	28	28	28	28	28
F	56	56	56	56	56	56	56

1: Values are average values and depend on the type (= on the line) of the resistance ribbon used

- With threaded rod

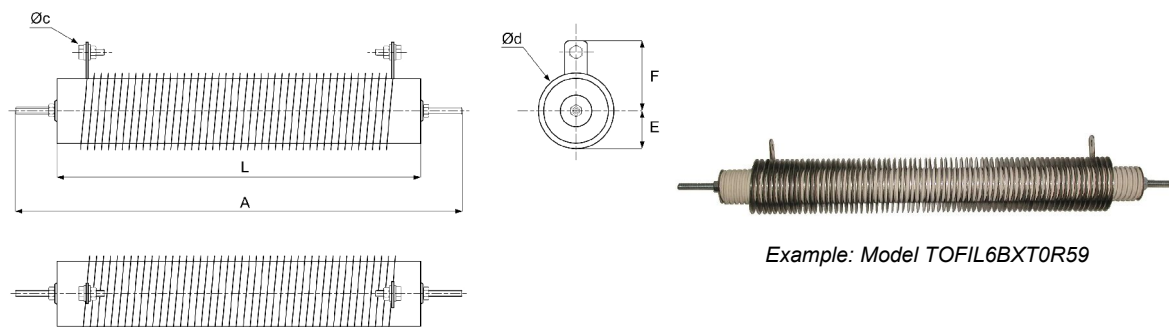

Example: Model TOFIL6BXT0R59

(mm)	TOFIL-1	TOFIL-2	TOFIL-3	TOFIL-4	TOFIL-5	TOFIL-6	TOFIL-7
A	170	236	314	386	446	524	596
Øc	8.5	8.5	8.5	8.5	8.5	8.5	8.5
Ød¹	56	56	56	56	56	56	56
E	28	28	28	28	28	28	28
L	90	156	234	306	366	444	516
F	56	56	56	56	56	56	56

1: Values are average values and depend on the type (= on the line) of the resistance ribbon used

- PS mounting brackets

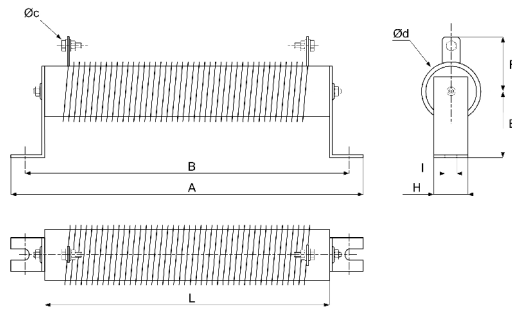

Example: Model TOFIL4CXPSX0R9

(mm)	TOFIL-1	TOFIL-2	TOFIL-3	TOFIL-4	TOFIL-5	TOFIL-6	TOFIL-7
A	132	198	276	328	408	486	558
B	117	183	261	333	393	471	543
Øc	8.5	8.5	8.5	8.5	8.5	8.5	8.5
Ød¹	56	56	56	56	56	56	56
E	45	45	45	45	45	45	45
L	90	156	234	306	366	444	516
F	56	56	56	56	56	56	56
I	9	9	9	9	9	9	9
H	30	30	30	30	30	30	30

1 : Values are average values and depend on the type (= on the line) of the resistance ribbon used

- ID mounting brackets

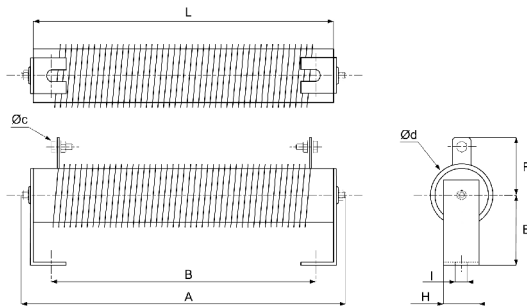

Example: Model TOFIL6BXID0R59

(mm)	TOFIL-1	TOFIL-2	TOFIL-3	TOFIL-4	TOFIL-5	TOFIL-6	TOFIL-7
A	90	156	236	306	366	444	516
B	116	182	260	332	392	470	542
Øc	8.5	8.5	8.5	8.5	8.5	8.5	8.5
Ød¹	56	56	56	56	56	56	56
E	45	45	45	45	45	45	45
L	90	156	234	306	366	444	516
F	56	56	56	56	56	56	56
I	9	9	9	9	9	9	9
H	30	30	30	30	30	30	30

1 : Values are average values and depend on the type (= on the line) of the resistance ribbon used

BC Resistors

- Unmounted resistor

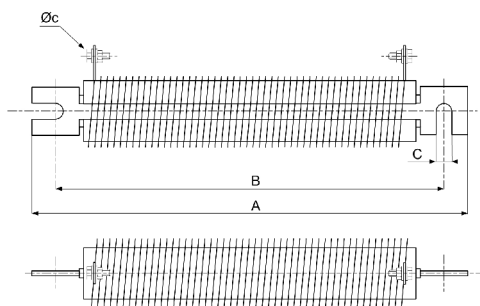

Example: Model BC4CXSS1R5

(mm)	BC-1	BC-2	BC-3	BC-4	BC-5	BC-6	BC-7	BC-8	BC-9
A	118	191	266	338	413	486	561	631	709
B	94	167	244	314	389	462	537	607	685
C	10.2	10.2	10.2	10.2	10.2	10.2	10.2	10.2	10.2
Øc	8.5	8.5	8.5	8.5	8.5	8.5	8.5	8.5	8.5
E	28	28	28	28	28	28	28	28	28
F	56	56	56	56	56	56	56	56	56
Ød¹	56	56	56	56	56	56	56	56	56

1: Values are average values and depend on the type (= on the line) of the resistance ribbon used

- PS mounting brackets

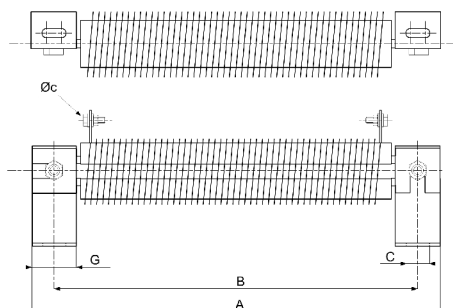

Example : Model BC4CXPSS1R5

(mm)	BC-1	BC-2	BC-3	BC-4	BC-5	BC-6	BC-7	BC-8	BC-9
A	118	191	266	338	413	486	561	631	709
B	94	167	244	314	389	462	537	607	685
C	14	14	14	14	14	14	14	14	14
D	8.5	8.5	8.5	8.5	8.5	8.5	8.5	8.5	8.5
E	60	60	60	60	60	60	60	60	60
F	56	56	56	56	56	56	56	56	56
Øc	8.5	8.5	8.5	8.5	8.5	8.5	8.5	8.5	8.5
Ød¹	56	56	56	56	56	56	56	56	56
G	30	30	30	30	30	30	30	30	30

1: Values are average values and depend on the type (= on the line) of the resistance ribbon used

- BC resistor for “secondary insulation”

BC resistors for “secondary insulation” have a slotted mounting bar which can be mounted with secondary ceramic insulators. The insulators are not supplied with the resistors in this configuration.

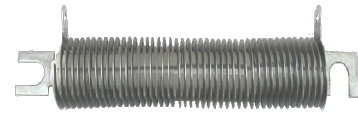
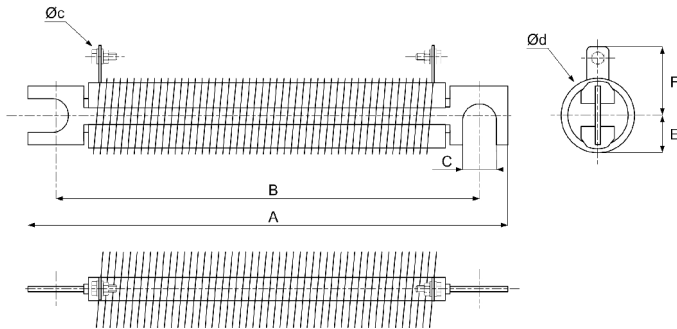

Example: Model BC4CXXSS1R5

(mm)	BC-1	BC-2	BC-3	BC-4	BC-5	BC-6	BC-7	BC-8	BC-9
A	128	201	276	349	423	496	571	641	719
B	95	168	242	315	390	463	538	611	685
C	19	19	19	19	19	19	19	19	19
Øc	8.5	8.5	8.5	8.5	8.5	8.5	8.5	8.5	8.5
E	28	28	28	28	28	28	28	28	28
F	56	56	56	56	56	56	56	56	56
Ød¹	56	56	56	56	56	56	56	56	56

1: Values are average values and depend on the type (= on the line) of the resistance ribbon used

- BC resistor with “secondary insulation” (option)

The resistors here the same as above but are supplied with the insulators: 2 two-piece insulators - not mounted on the resistors – provide secondary insulation at both ends of the resistor.

Dimensions of the insulators :

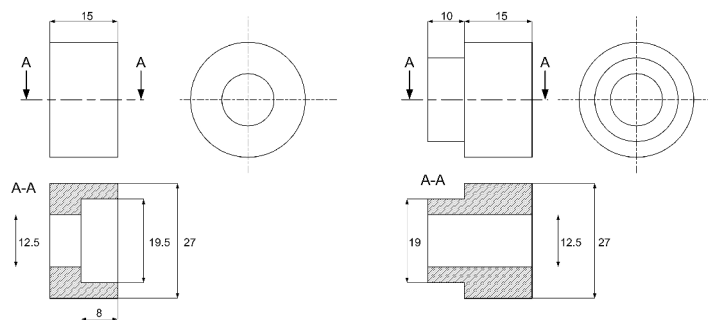

Two-piece insulator

Example of a BC resistor with “secondary insulation” :



3.3.3 Terminals

Connections to the BC and TOFIL resistors are made by nuts and screws on the ends and optionally on intermediary terminals.

Screws for each terminal are supplied with the resistors (included : screw, nut, washer and lock-washer, plus a specific part called a "fork" for the BC resistors).

» **Welded terminal** at both ends of the resistor and optionally as intermediary lugs

The resistors can be fitted with one or more welded intermediary lugs. Their size is the same as the size of the terminals at the ends of the resistor, described in the drawings on the previous pages.



TOFIL resistor with welded intermediary lug



BC resistor with welded intermediary lug

» **Adjustable terminal**

The resistors can be fitted with one or more optional adjustable terminals :

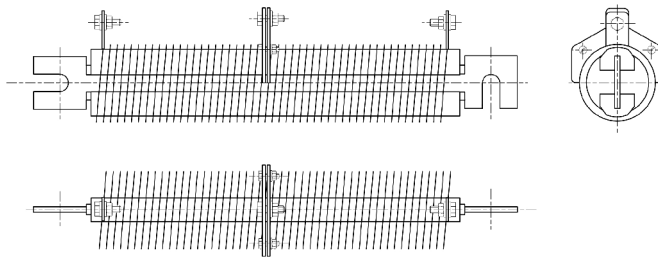

Example of adjustable terminal on a BC resistor

3.3.4 Weights

➤ **Weights of TOFIL resistors** (approximate values in grams, brackets excluded)

Line N°	TOFIL-1	TOFIL-2	TOFIL-3	TOFIL-4	TOFIL-5	TOFIL-6	TOFIL-7
1	465	840	1200	1670	2055	2480	2915
2	405	715	1060	1400	1715	2065	2425
3	370	635	940	1235	1505	1760	2175
4	505	925	1400	1785	2285	2790	3225
5	405	715	1070	1405	1715	2070	2425
6	370	650	965	1260	1540	1865	2170
7	320	540	795	1040	1260	1505	1760
8	300	500	725	950	1140	1375	1600
9 and 16	390	670	1025	1340	1645	1990	2315
10 and 17	355	600	905	1130	1445	1735	2020
11 and 18	318	530	795	1035	1255	1505	1760
12 and 19	310	500	755	980	1190	1430	1670
13 and 20	280	450	665	860	1030	1635	1460
14 and 21	270	430	625	810	975	1160	1350
15	445	775	1200	1585	1945	2340	2725

➤ **Weights of BC resistors** (approximate values in grams, brackets and insulators excluded)

Line N°	BC-1	BC-2	BC-3	BC-4	BC-5	BC-6	BC-7	BC-8	BC-9
1	430	805	1140	1645	2075	2495	2925	3300	3790
2	370	680	1000	1375	1735	2080	2435	2720	3150
3	335	600	880	1210	1525	1775	2185	2440	2730
4	470	890	1340	1720	2235	2710	3130	3550	4090
5	370	680	1010	1340	1665	1990	2330	2650	3030
6	335	615	910	1195	1490	1785	2075	2345	2680
7	285	505	736	975	1210	1424	1665	1885	2165
8	265	465	665	885	1090	1295	1505	1695	1945
9 and 16	355	635	965	1275	1595	1910	2220	2500	2870
10 and 17	320	565	845	1065	1395	1655	1925	2195	2515
11 and 18	285	495	735	970	1205	1425	1665	1880	2165
12 and 19	275	465	700	915	1140	1350	1575	1775	2035
13 and 20	245	415	605	795	980	1155	1365	1515	1735
14 and 21	235	395	565	745	925	1080	1255	1415	1615
15	410	740	1140	1560	1965	2355	2735	3120	3980

3.4 Product Identification Code

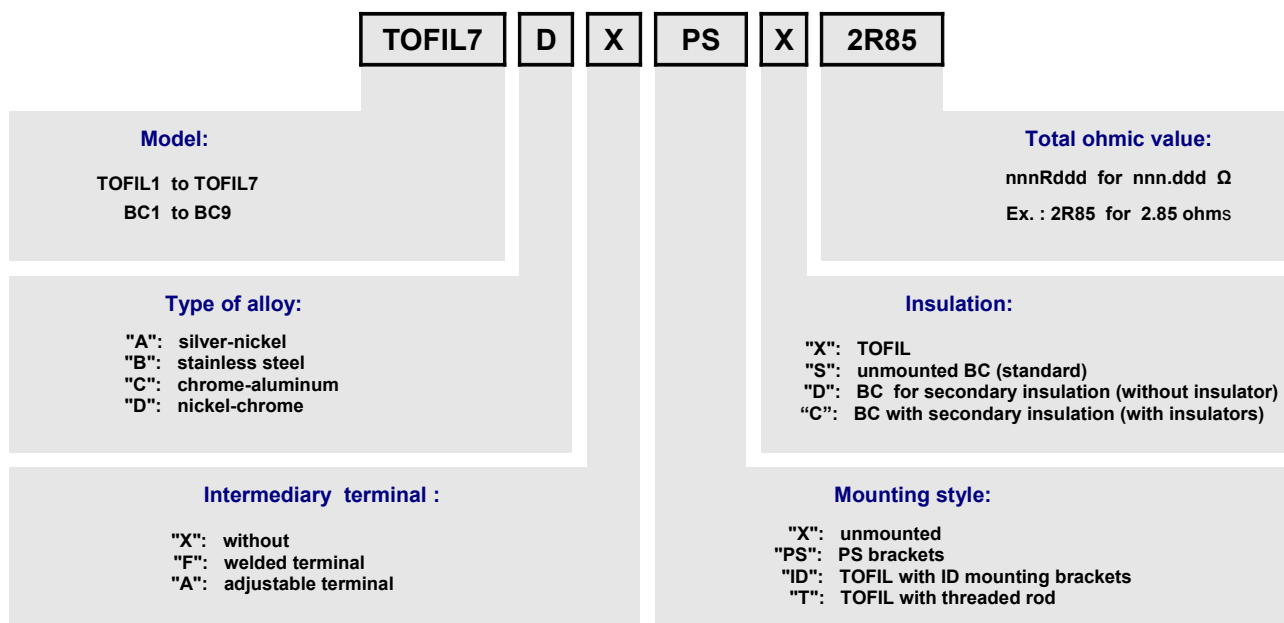

This identification code above is followed:

- when ordering, from the list of the optional features which are not described in the code,
- Internally from a special code if the product cannot be considered as a standard model.

4 Other Series and Models

4.1 "ZOFIL" Series

The ZOFIL series is designed for "traction" (railway) applications.

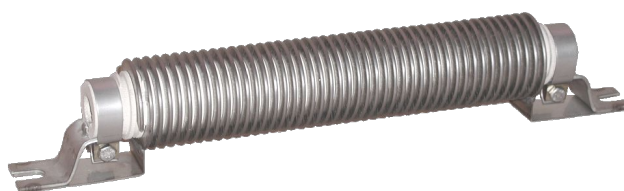

Example of ZOFIL series resistor

- ♦ **Description** : The resistors in the ZOFIL series are constructed with:

 - a resistance coil (the same as in the TOFIL and BC series), in chromium-nickel alloy,
 - a one-piece grooved ceramic tube, designed to withstand a rapid temperature rise of 800°C,
 - brackets-terminals welded to the resistance coil.
- ♦ **Characteristics**: In this series, there are 3 models/sizes with 14 possible ohmic values for each, which use the same resistance ribbon in alloy D (nickel-chromium) as the TOFIL and BC of lines 15 to 21 (other values possible on request).

The instantaneous energy and the rated currents for temperature rises of 300°C, 350°C and 400°C are given by model and line number (/ohmic values) in the following table (maximum working temperature: 600°C, including ambient temperature).

Please contact us for more information.

Line number		15	16	17	18	19	20	21
Model ZOFIL-4	Ohmic value (Ω)	0.38	0.57	0.735	1.00	1.10	1.65	2.2
	Energy (kJ)	217	146	123	84	69	49	36
Model ZOFIL-5	Ohmic value (Ω)	0.49	0.72	0.93	1.24	1.38	2.08	2.78
	Energy (kJ)	275	185	143	107	89	60	45
Model ZOFIL-6	Ohmic value (Ω)	0.59	0.87	1.13	1.50	1.68	2.52	3.36
	Energy (kJ)	337	227	173	130	108	75	55
Current (Amps) for a temperature rise of 300°C		44	36	31	27	24	20	18
Current (Amps) for a temperature rise of 375°C		52	42	36	32	29	24	21
Current (Amps) for a temperature rise of 450°C		60	49	42	38	34	28	25

Main characteristics for ZOFIL-4 to ZOFIL-6

4.2 M17 Series



M17 resistors are similar to BC resistors, but the mounting bar and ceramic insulators are different, requiring a different mounting mode and a different step in the resistance coil.

They are supplied to replace old parts, based on the designation of the resistor to be replaced.

5 Edgewound Resistor Assemblies

Resistor assemblies can be supplied as open frames, available to OEM's for mounting in their own enclosure. or in indoor/outdoor enclosures.

5.1 Open Frame Constructions

Zinc-plated steel brackets are used as the standard. Aluminum, stainless steel or painted steel may be used on request. Terminal connections may be made as in the resistor terminals or may be done by connecting plugs or blocks.

Examples of open frame assemblies using edgewound resistors:



E1507
(railway application)

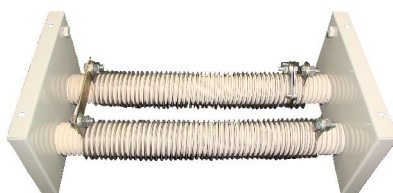

E1510
(painted steel brackets)

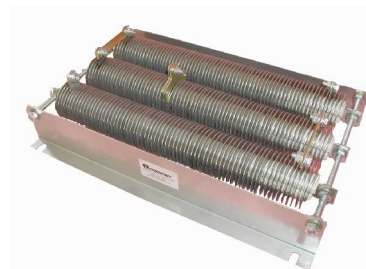

E1391
(BC resistors)

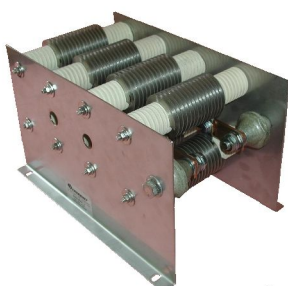

E1360
(TOFIL resistors)



E1007
(railway application)



E1462
(BC resistors)



E1463
(BC resistors)

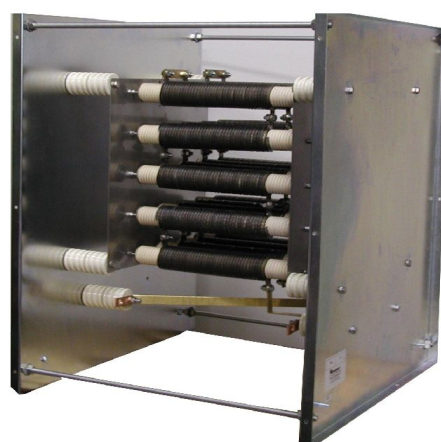

E1395
(operating voltage: 11 kV)

5.2 Resistor Enclosures

Resistors or resistor assemblies can be packaged in metallic boxes/enclosures/cages to meet a required protection level, usually IP20 to IP23.

Enclosures are made of white zinc plated steel, or optionally of painted steel, aluminum or stainless steel.

Terminal connections can be done using connecting sockets, connecting blocks on the front, side or rear panels, a screw-fastened door for user protection, etc.

Other accessories may be added, such as switches. When the ohmic value can be selected by switches, the resistor box is considered as a bench or a load bank, described in a separate document.

Examples of edgewound resistor assemblies in cages/boxes/enclosures:



*E1461
(IP 20)*



*E1548
(IP 20)*



*E1551
(IP 20)*



*E1540
(mobile /with fans)*



*E1394
(IP 23)*

COUDOINT

Tel.: +33 1 30 41 55 00

Fax: +33 1 30 41 55 62

Email: commercial@coudoint.com

Website: www.coudoint.com

Address: 19 Avenue de la gare 78690 Les Essarts Le Roi FRANCE